

Product Brief 2019

Sensors for Automotive Applications

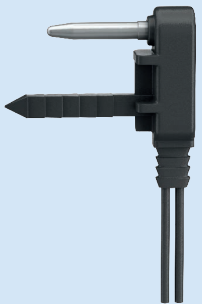

Sensors for Automotive Applications

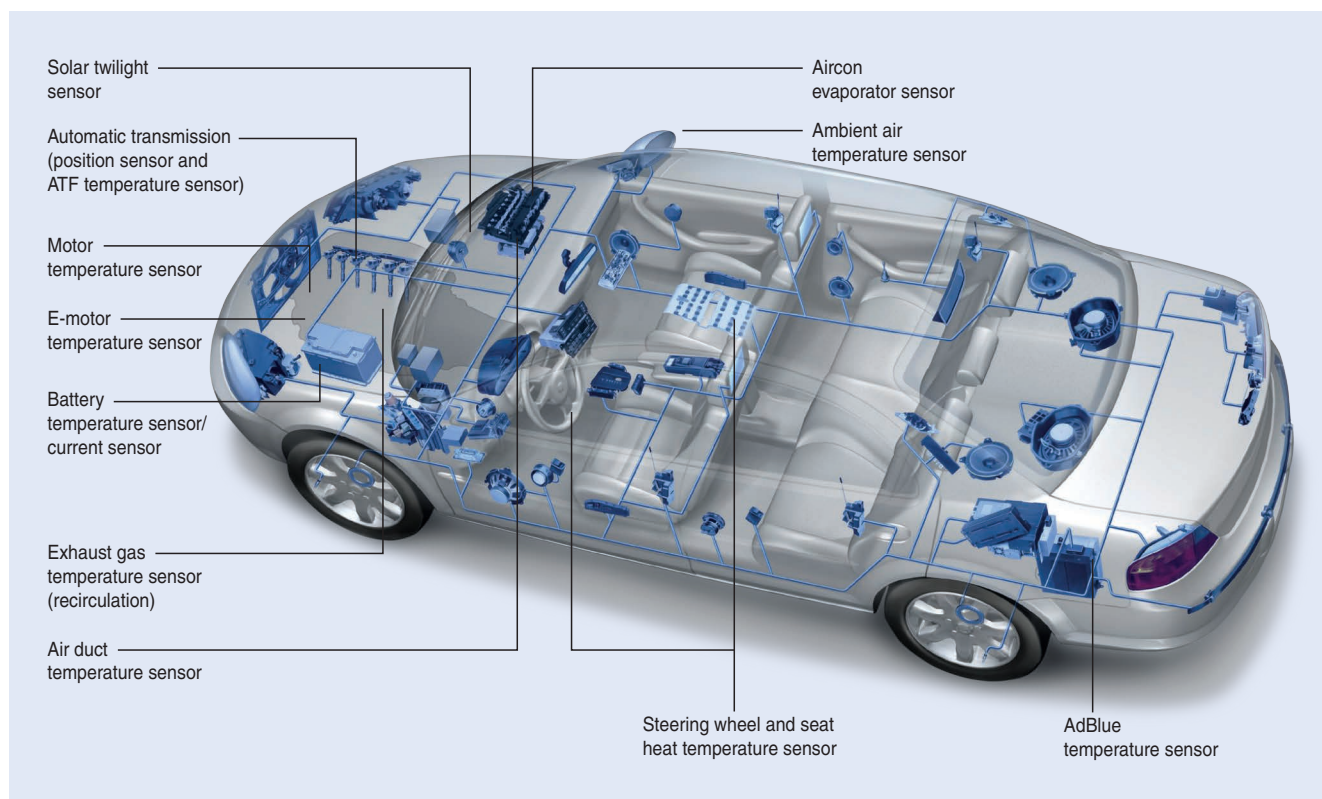

Temperature sensing and control are among the most important and well-established functions in automotive electronics. In automotive electronics they are found especially in climate control and powertrain applications.

In recent years we have introduced a great variety of new sensors and sensor systems to the automotive market and continuously develop innovative products to meet customers' requirements.

EPCOS sensors stand out for excellent measuring accuracy and long-term stability. Advanced technologies allow cost-efficient and large-scale production of reliable sensors. Thus, we are able to offer sensors overmolded with plastic or encapsulated in specific materials for reliable use in adverse environments for a large range of temperatures. They can be delivered in numerous shapes and with a wide variety of cable and connector geometries.

If standard types do not match the purpose – we can also supply application-specific sensors with customized parameters.

Our design centers and plants for sensor products – in Berlin, Germany, Deutschlandsberg, Austria, Zhuhai, China, and Batam, Indonesia – are certified to ISO 9001:2008, ISO/TS 16949:2009 and ISO 14001:2004.

With our comprehensive sensor portfolio we help automotive manufacturers make their products safer, more convenient to use and more energy-efficient.

This product brief can only present a selection of our continuously growing portfolio of both temperature and pressure sensor products.

In addition to the presented temperature sensors, we also offer an extensive range of pressure sensors that are suitable for automotive industry. For example, pressure sensors can be used to measure the pressure of various media and thus support engine management and safety systems. Such sensors are needed to achieve precise engine control for low fuel consumption and to enable exhaust gas treatment for a reduction of harmful emissions.

Climate Control

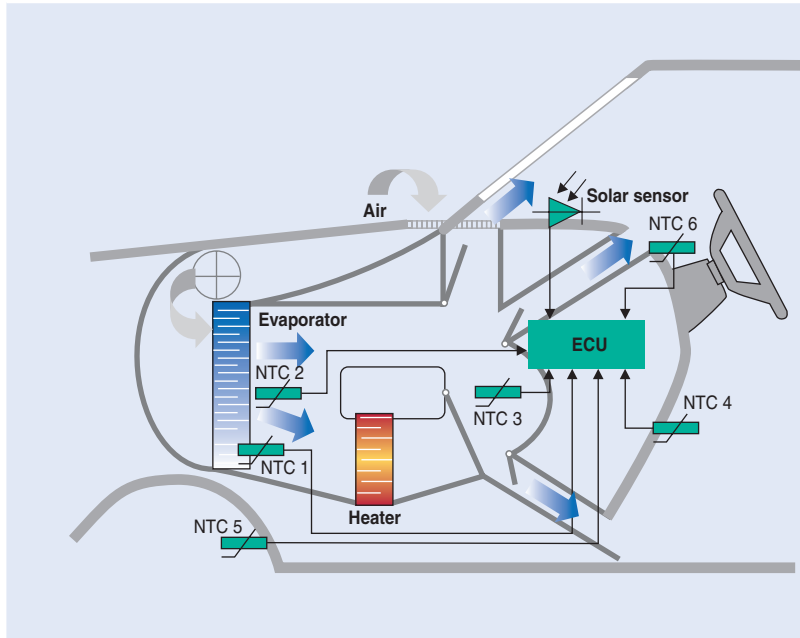



Climate control



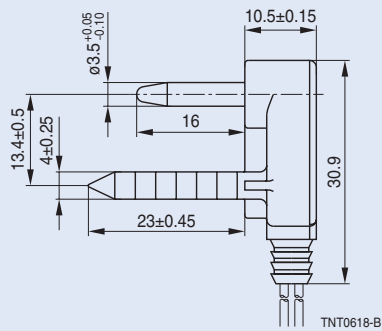

Effective air-conditioning helps drivers keep a cool head in the most tricky situations and minimizes the stress on passengers. The control of the air-conditioning system can be based on the temperature at the evaporator or in the air streams of every outlet carrying air to the feet or body of the passengers.

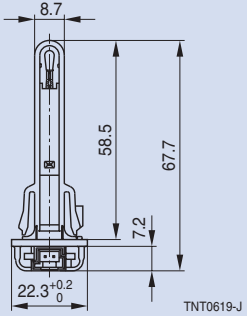
One effect that temperature sensors are unable to detect is the warmth of direct sunlight that passengers feel on their skin. In this case, solar sensors can be used to evaluate the intensity and in many cases the direction of incoming solar rays.

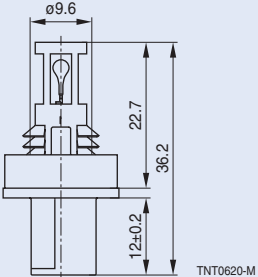

Type	Characteristics	Features	Dimensional drawing
Evaporator fin temperature sensor 	<ul style="list-style-type: none"> Temperature range: $-40 \dots +85 \text{ }^\circ\text{C}$ Customer-specific solutions 	<ul style="list-style-type: none"> Humidity resistant: 3000 h immersion test at $+80 \text{ }^\circ\text{C}$ Response time: $< 6 \text{ s}$ in water Cable-based design Insulated wires with high insulation voltage 	 <p>TNT0618-B</p>
Evaporator air temperature sensor 	<ul style="list-style-type: none"> Temperature range: $-40 \dots +100 \text{ }^\circ\text{C}$ Customer-specific solutions 	<ul style="list-style-type: none"> Humidity resistant: 2000 h immersion test at $+25 \text{ }^\circ\text{C}$ Response time: $< 3 \text{ s}$ in water, $< 8 \text{ s}$ in air at 5 m/s Connector molded directly on the sensor Clip design for fast and reliable mounting 	 <p>TNT0619-J</p>

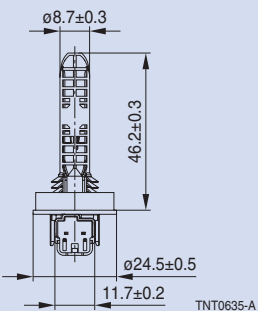
Climate Control

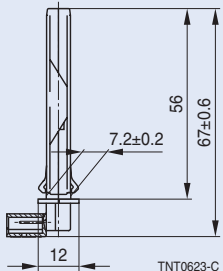
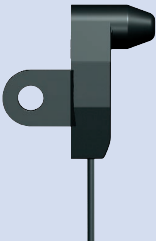
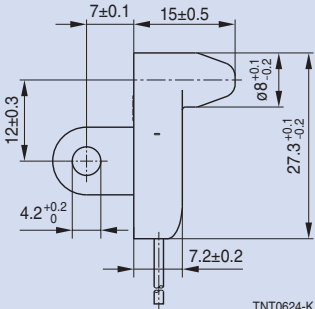
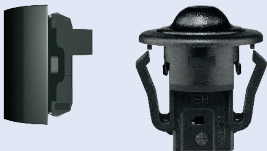
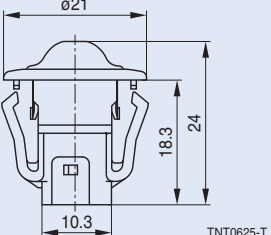
Type	Characteristics	Features	Dimensional drawing
Point air duct sensor 	<ul style="list-style-type: none"> Temperature range: -40 ... +90 °C Customer-specific solutions 	<ul style="list-style-type: none"> Response time: < 5 s in air at 5 m/s 72 h salt spray test Connector molded directly on the sensor Clip design for fast and reliable mounting 	 <p>TNT0620-M</p>
Integrating round air duct sensors 	<ul style="list-style-type: none"> Temperature range: -40 ... +90 °C Customer-specific solutions 	<ul style="list-style-type: none"> Response time: < 12 s in air at 5 m/s 24 h salt spray test Connector molded directly on the sensor Bayonet fitting for fast and reliable mounting 	 <p>TNT0635-A</p>
Integrating angular air duct sensor 	<ul style="list-style-type: none"> Temperature range: -40 ... +90 °C Customer-specific solutions 	<ul style="list-style-type: none"> Response time: < 15 s in air at 5 m/s Up to 144 h salt spray test Connector molded directly on the sensor Clip design for fast and reliable mounting 	 <p>TNT0623-C</p>
Outside temperature sensor 	<ul style="list-style-type: none"> Temperature range: -40 ... +85 °C Compliant to IP6K6 and IPX9K for 30 s Customer-specific solutions 	<ul style="list-style-type: none"> Humidity resistant: 2000 h immersion test at +80 °C Thermal cycling: 480 cycles with applied voltage 120000 cycles on/off Thermal shock: 200 cycles in air transition time < 30 s Cable based design 	 <p>TNT0624-K</p>
Solar sensor with optional twilight function 	<ul style="list-style-type: none"> Temperature range: -40 ... +100 °C Customer-specific solutions 	<ul style="list-style-type: none"> Mono and dual zone with optional twilight function High resolution and sensitivity Adapted angular characteristics Analog signal 	 <p>TNT0625-T</p>

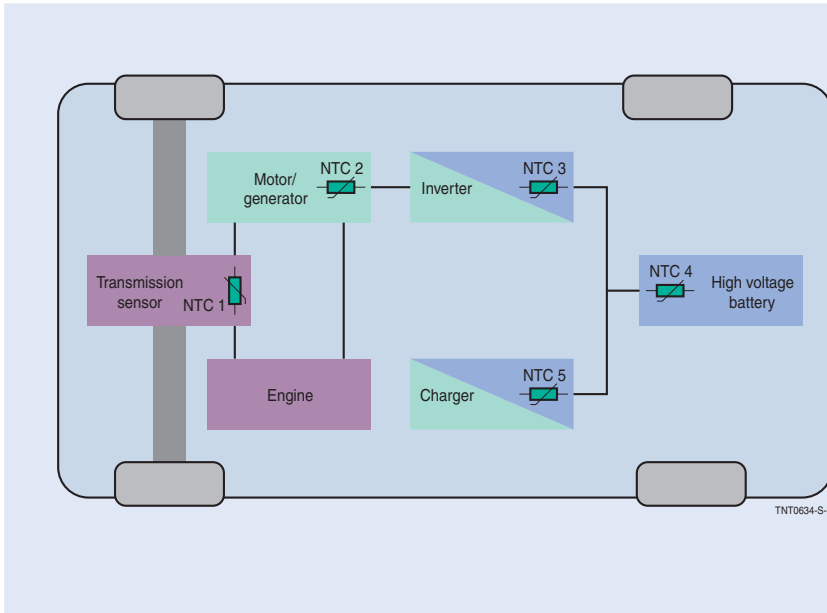





Thermal management and automatic transmissions

Temperature sensors in xEV applications must cover a wide range of operating temperatures, high shock resistance and vibrational strength, high reliability and long term stability – even under harsh operating conditions. They are used to measure the temperature of the battery in both cell and coolant as well as motor and transmission oils. For these applications EPCOS offers sensors with a high temperature range up to 250 °C and with different mounting solutions to meet a wide variety of demands.

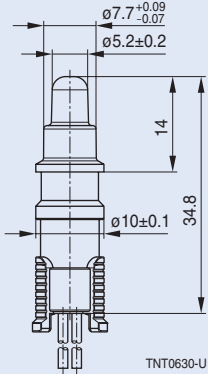

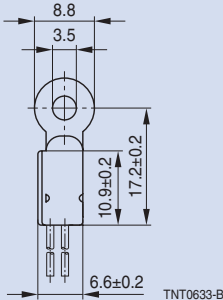
Type	Characteristics	Features	Dimensional drawing
<p>Motor temperature sensor</p>	<ul style="list-style-type: none"> Temperature range: +40 ... +200 °C Customer-specific solutions 	<ul style="list-style-type: none"> Humidity resistant: 500 h test at +40 °C with 93% humidity Thermal cycling: 21 days without voltage Cable-based design 	<p>TNT0628-K</p>
<p>Clip-on battery fluid sensor</p>	<ul style="list-style-type: none"> Temperature range: -40 ... +100 °C Customer-specific solutions 	<ul style="list-style-type: none"> Thermal cycling: 240 h with applied voltage 2 hours on/off Response time: < 20 s in water Cable-based design Clip design for fast and reliable mounting at different tube diameters 	<p>Rubber</p> <p>Sensor suitable for tube diameter 6±0.1 mm</p> <p>TNT0629-F-E</p>

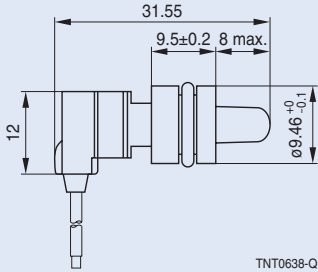
Type	Characteristics	Features	Dimensional drawing
<p>Battery coolant sensor</p> 	<ul style="list-style-type: none"> Temperature range: -40 ... +100 °C Customer-specific solutions 	<ul style="list-style-type: none"> Response time: < 20 s in oil Thermal cycling: 240 h with applied voltage Design allows direct detection of battery fluid Cable based design 	 <p>TNT0630-U</p>
<p>Screw-on battery sensor</p> 	<ul style="list-style-type: none"> Temperature range: -40 ... +100 °C Customer-specific solutions 	<ul style="list-style-type: none"> Response time: < 20 s in silicone oil Thermal cycling: 240 h with applied voltage Humidity resistance: 240 h test at -40 ... +65 °C with 93% humidity Screw design for fast and reliable mounting Cable based design 	 <p>TNT0633-B</p>
<p>Transmission oil sensor</p> 	<ul style="list-style-type: none"> Temperature range: -40 ... +150 °C Customer-specific solutions 	<ul style="list-style-type: none"> Response time: 9 s in oil High heat, oil and ATF resistance O-ring allows direct detection of oil temperature Cable based design 	 <p>TNT0638-Q</p>

TDK EPCOS

Important information: Some parts of this publication contain statements about the suitability of our products for certain areas of application. These statements are based on our knowledge of typical requirements that are often placed on our products. We expressly point out that these statements cannot be regarded as binding statements about the suitability of our products for a particular customer application. It is incumbent on the customer to check and decide whether a product is suitable for use in a particular application. This publication is only a brief product survey which may be changed from time to time. Our products are described in detail in our data sheets. The *Important notes* (www.tdk-electronics.tdk.com/ImportantNotes) and the product-specific *Cautions and warnings* must be observed. All relevant information is available through our sales offices.